

3030173, 74 DB
 3032829, 30 DB MW** IP44
 3032867, 68 DALI
 3032881, 82 DALI MW**
 3032917, 18 EB
 3032921, 22 MW**
 3032925, 26 E3
 3032933, 34 DALI E3
 3032942, 43 E1
 3032950, 51 DB E1
 3032958, 59 DALI E1

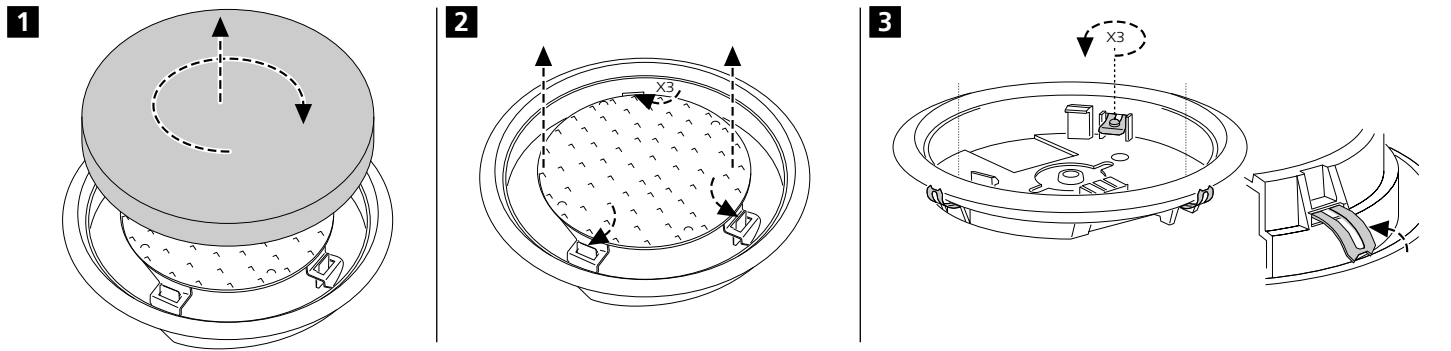

230-240V~ 50-60Hz

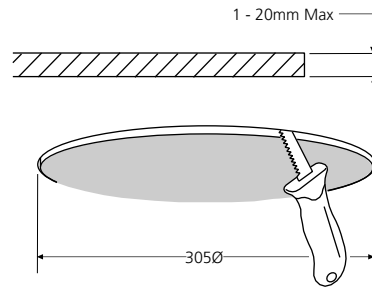
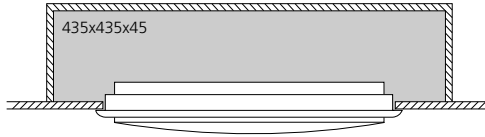
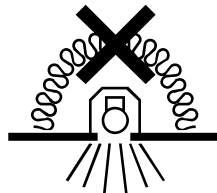

4 ⚡ - 230-240V~ 2 x 0.75mm² Min. P/L, N.
 DIM - 2 x 0.75mm² Min. +, -. DALI - 2 x 0.75mm² Min D1, D2. MW - 2 x 0.75mm² Min.

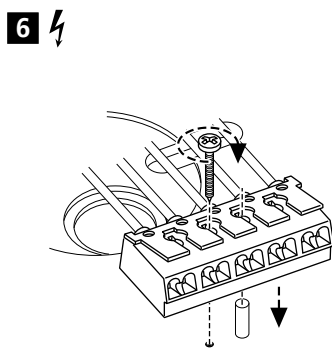
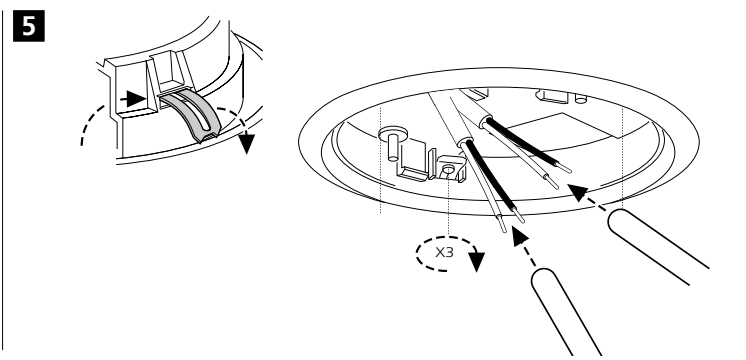
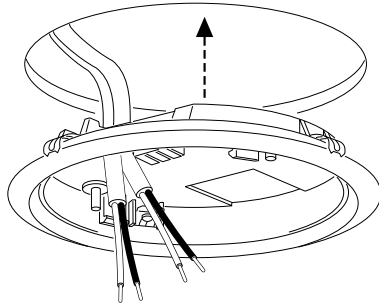

3030173, 74 DB
 3032867, 68 DALI
 3032917, 18 EB

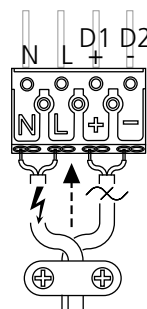

3032921, 22 MW

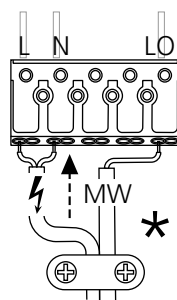

3032942, 43 E1
 3032925, 26 E3

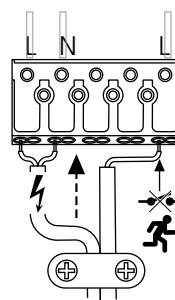

3032950, 51 DB + E1
 3032958, 59 DALI + E1
 3032929, 30 DB + E3
 3032933, 34 DALI + E3

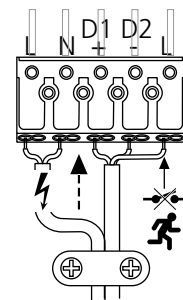

3032829, 30 DB + MW
 3032881, 82 DALI + MW

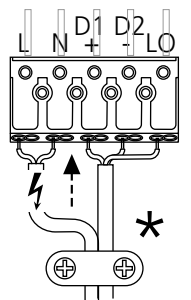

3032925, 26 E3
 3032929, 30 DB E3
 3032933, 34 DALI E3
 3032942, 43 E1
 3032950, 51 DB E1
 3032958, 59 DALI E3

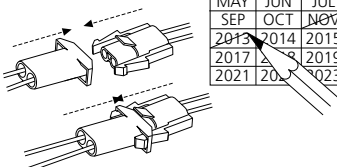

JAN	FEB	MAR	APR
MAY	JUN	JUL	AUG
SEP	OCT	NOV	DEC
2013	2014	2015	2016
2017	2018	2019	2020
2021	2022	2023	2024

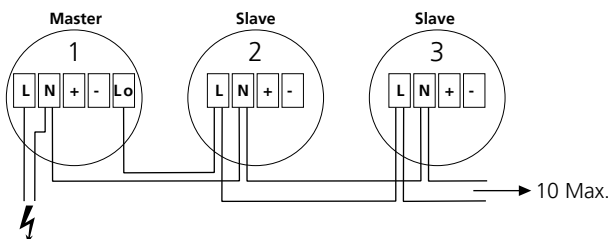

10 Max.

