

3030171, 72 DB
 3034831, 32 DB MW
 3032869, 70 DALI
 3032919, 20 EB
 3034923, 24 MW

3032927, 28 E3
 3032935, 36 DALI E3
 3032944, 45 E1
 3032952, 53 DB E1
 3032960, 61 DALI E1

ta 25°C



1

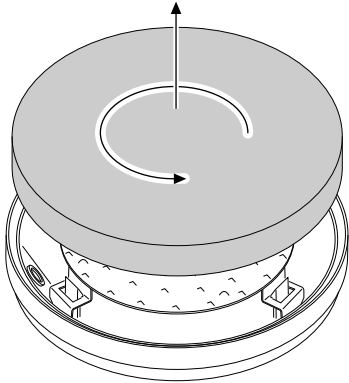

2

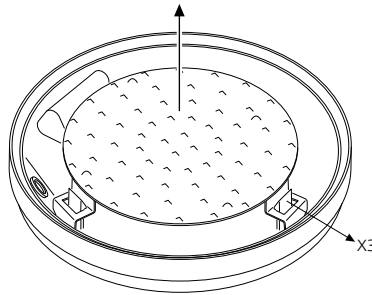

3

⚡ - 230-240V~ 3 x 0.75mm: Min. 2 x P/L, N.
 DIM - 2 x 0.75mm: Min. +, -
 DALI - 2 x 0.75mm: Min D1, D2.
 MW - 1 x 0.75mm: Min.

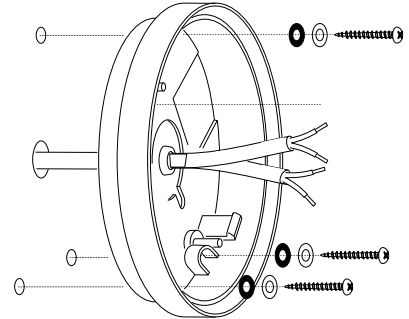

4

⚡ ! ENSURE DRIVER HAS NOT BEEN POWERED FOR AT LEAST 1(ONE) MINUTE BEFORE CONNECTING LED STRING.

EB Version
 3032919, 920 EB

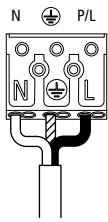

DA / 1-10V version
 3030171, 72 DB
 3032869, 70 DALI

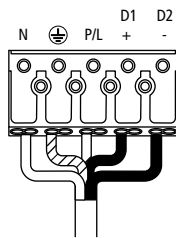

E3 / E1 version
 3032944, 45 E1 3032927, 28 E3

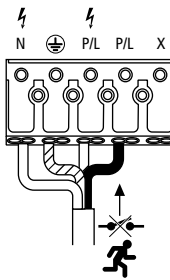

DA / 1-10V + E3 / E1 version
 3032952, 53 DB + E1 3032931, 32 DB + E3
 3032960, 61 DALI + E1 3032935, 36 DALI + E3

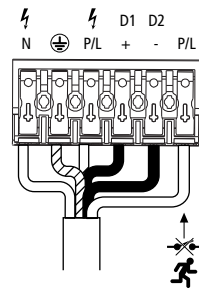

MW version
 3034923, 24 EB MW

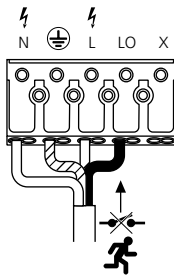

1-10V + MW version
 3034831, 32 DB + MW

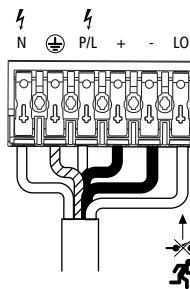

5

3032927, 28 E3 3032944, 45 E1
 3032931, 32 DB E3 3032952, 53 DB E1
 3032935, 36 DALI E3 3032960, 61 DALI E1

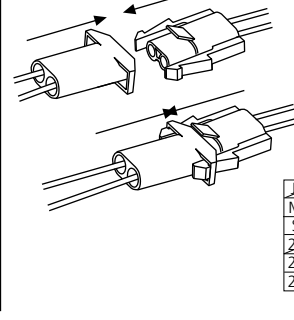

6

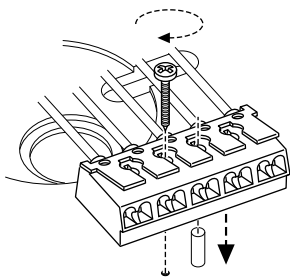

7

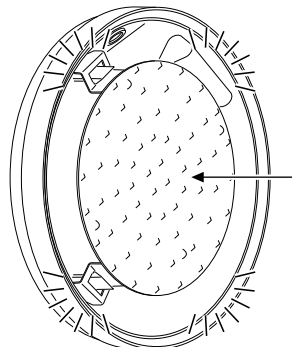

8

