



	OUT W	lm	T <sub>c</sub> (K)	L x W x H (mm)	OPAL
0055310	36 W	3750 lm	3000 K	595 x 595 x 105	OPAL
0055312	36 W	3950 lm	4000 K	595 x 595 x 105	OPAL
0055320	44 W	4550 lm	3000 K	595 x 595 x 105	OPAL
0053322	44 W	4900 lm	4000 K	595 x 595 x 105	OPAL
0055311	36 W	3750 lm	3000 K	595 x 595 x 105	OPAL
0055313	36 W	3950 lm	4000 K	595 x 595 x 105	OPAL
0053321	44 W	4550 lm	3000 K	595 x 595 x 105	OPAL
0053323	44 W	4900 lm	4000 K	595 x 595 x 105	OPAL
0055314	38 W	3950 lm	3000 K	1195 x 295 x 105	OPAL
0055316	38 W	4150 lm	4000 K	1195 x 295 x 105	OPAL
0055315	38 W	3950 lm	3000 K	1195 x 295 x 105	OPAL
0055317	38 W	4150 lm	4000 K	1195 x 295 x 105	OPAL
0053324	36 W	3750 lm	3000 K	595 x 595 x 80	PAR
0053326	36 W	3900 lm	4000 K	595 x 595 x 80	PAR
0055328	46 W	4550 lm	3000 K	595 x 595 x 80	PAR
0055330	46 W	4750 lm	4000 K	595 x 595 x 80	PAR
0053325	36 W	3750 lm	3000 K	595 x 595 x 80	PAR
0053327	36 W	3900 lm	4000 K	595 x 595 x 80	PAR
0055329	46 W	4550 lm	3000 K	595 x 595 x 80	PAR
0055331	46 W	4750 lm	4000 K	595 x 595 x 80	PAR
0055332	36 W	3750 lm	3000 K	1195 x 295 x 80	PAR
0055334	36 W	3900 lm	4000 K	1195 x 295 x 80	PAR
0055333	36 W	3750 lm	3000 K	1195 x 295 x 80	PAR
0055335	36 W	3900 lm	4000 K	1195 x 295 x 80	PAR

## SYL-LAB LED RECESSED

INSTRUKCJA MONTAŻU | ИНСТРУКЦИЯ ПО МОНТАЖУ | MONTAGEANLEITUNG | INSTRUCTIONS DE MONTAGE | NÁVOD K MONTÁŽI | SZERELÉSI UTASÍTÁSOK  
 MONTERINGSVEJLEDNING | INSTRUÇÕES DE MONTAGEM | MONTERINGSVEJLEDNING | INSTRUCCIONES DE MONTAJE | KOKOONPANO - JA KIINNITYSOHJEET  
 MONTAGE INSTRUCTIE | INSTRUZIONI DI MONTAGGIO | ИНСТРУКЦІЯ З МОНТАЖУ | MONTAJ YÖNERGESİ

- PL MONTAŻU POWINNA DOKONAĆ OSOBA POSIADAJĄCA ODPOWIEDNIE UPRAWNIENIA.
- GB INSTALLATION MUST BE PERFORMED BY AN AUTHORIZED TECHNICIAN.
- FR LA MONTAGE DOIT FAIRE UNE PERSONNE QUI POSSEDER LES EXPERIENCES COMPETENTES.
- BRPT A INSTALAÇÃO TEM QUE SER FEITA POR UM TÉCNICO AUTORIZADO.
- RU МОНТАЖ НУЖЕН БЫТЬ СОВЕРШЕН ЧЕРЕЗ ЛИЦО ИМЕЮЩЕ СООТВЕТСТВЕННЫЕ ПРАВА.
- DE DIE MONTAGE MUSS VON EINER PERSON MIT ERFORDERLICHEN KENNNTNISSEN DURCHFÜHRT WERDEN.

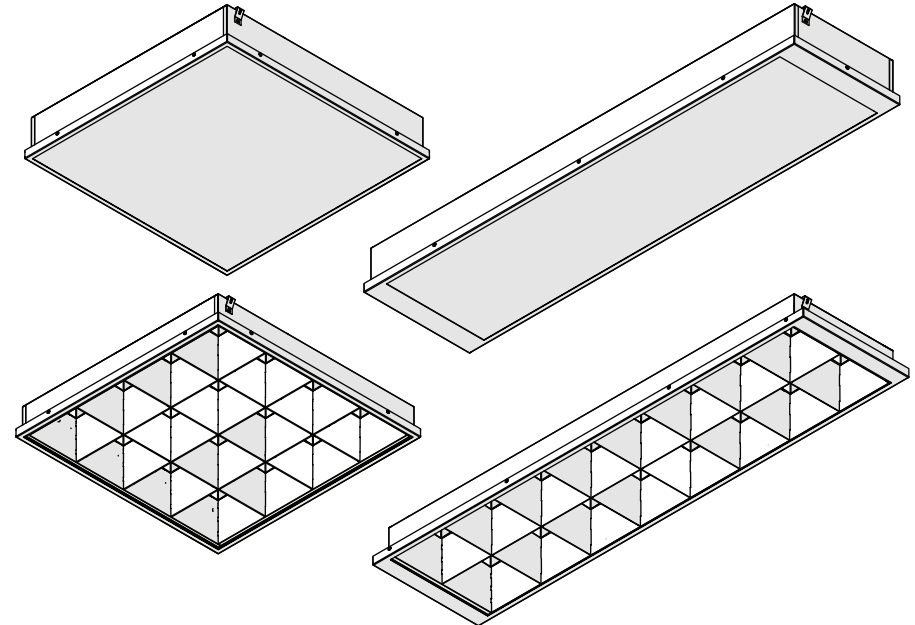

### WYMIARY | DIMENSIONS | DIMENSIONS | DIMENSIONES | РАЗМЕРЫ | ABMESSUNGEN

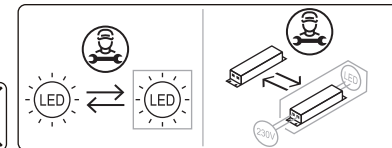
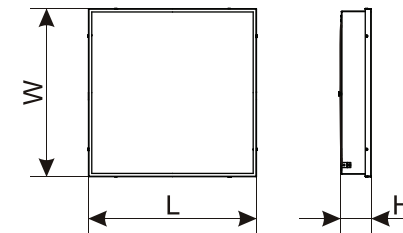



**Uwaga, ryzyko porażenia prądem.**  
**Caution, risk of electric shock.**



brown		L
yellow/green		PE
blue		N

**1 FAZA | 1 PHASE**

brown		1
blue		N
yellow/green		PE
black		2
gray		3

**DALI**

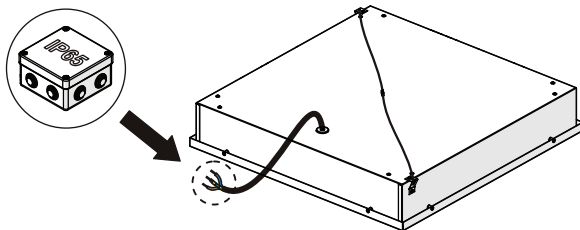

**MONTAŻ | MOUNTING | MONTAGE | MONTAJE | УСТАНОВКА | MONTAGE**

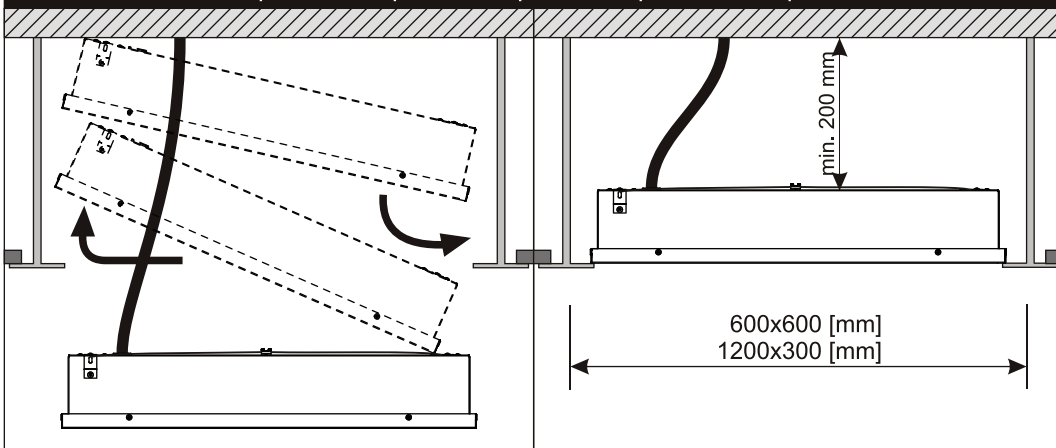

**PL | Do montażu w sufitach gips-kartonowych**  
 (g/k) stosować dodatkowe akcesorium!

**PT | Permet la pose dans un faux plafond à**  
 découpe (g/k) et nécessité l' utilisation d'accessoires!

**GB | For assembly in plaster-board ceilings**  
 use additional accessory!

**RU | Для монтажа в гипсокартонных потолках**  
 необходимо использовать дополнительное  
 аксессуары!

**FR | Permet la pose dans un faux plafond à**  
 découpe (g/k) et nécessité l' utilisation d'accessoires!

**DE | Für die Montage in der Gipskarton Decke**  
 bitte das zusätzliche Zubehör verwenden!

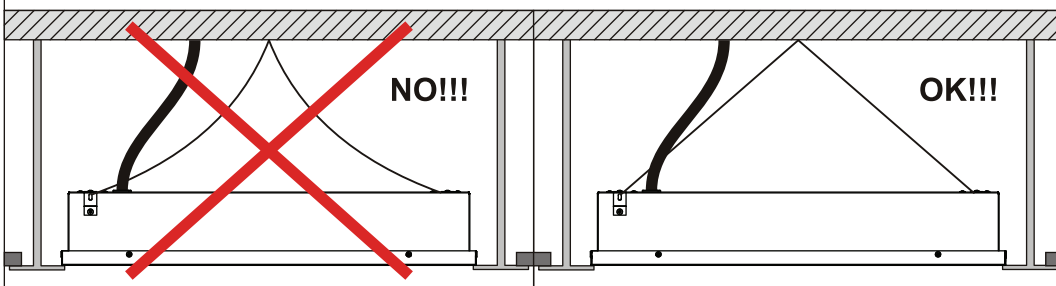

Podczas montażu oprawy oraz czynności konserwacyjnych zaleca się stosowanie rękawic ochronnych.  
 Use protective gloves during the montage.  
 Durant l'installation et l'entretien du luminaire il est recommande de mettre les gants de protection.  
 Use luvas de proteção durante a montagem.  
 При монтаже и обслуживании светильника рекомендуется использовать защитные перчатки.  
 Bei der montage bitte die mitgelieferten schutzhandschuhe verwenden.



Kurz lub inne zabrudzenia należy usuwać za pomocą ściereczek z microfibry.  
 Remove the dirt & dust with microfiber wipes.  
 La poussiere et les autres saletes il faut enlever en utilisant un tissu en microfibre.  
 Remova a sujeira e poeira com microfibrilimpra.  
 Пыль или другие загрязнения должны быть удалены салфеткой из микрофибры.  
 Staub und schmutz bitte mit einem microfasertuch entfernen.



Nie dotykać komponentów elektrycznych, wrażliwe na uszkodzenia ESD.  
 Do not touch electrical appliances. Electrostatic sensitive device (ESD).  
 Il est interdit de toucher les composants électriques, ils sont sensibles aux décharges electrostatiques.  
 Não toque os aparelhos elétricos. Dispositivo sensível eletrostático (DSE).  
 Не трогать электрических компонентов, чувствительные к esd.  
 Die elektronischen komponenten wegen einer möglichen elektrostatischen aufladung nicht anfassen.

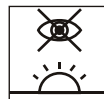

Unikać bezpośredniego patrzenia na źródła led.  
 Avoid direct looking at led source light.  
 Il faut éviter un regard direct sur les sources led.  
 Evite olhar direto para a fonte de luz led.  
 Не следует смотреть непосредственно на светодиодные источники света.  
 Den direkten augenkontakt in die led vermeiden.

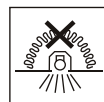

Nie przykrywać materiałem izolacyjnym.  
 Do not cover by insulating material.  
 Ne pas couvrir avec du matériau isolant.  
 Não cubra o material de isolante.  
 Не закрывать изоляционным материалом.  
 Nicht mit dämmplatten abdecken.