

DIMENSIONS (mm):

Energy Class : **A**

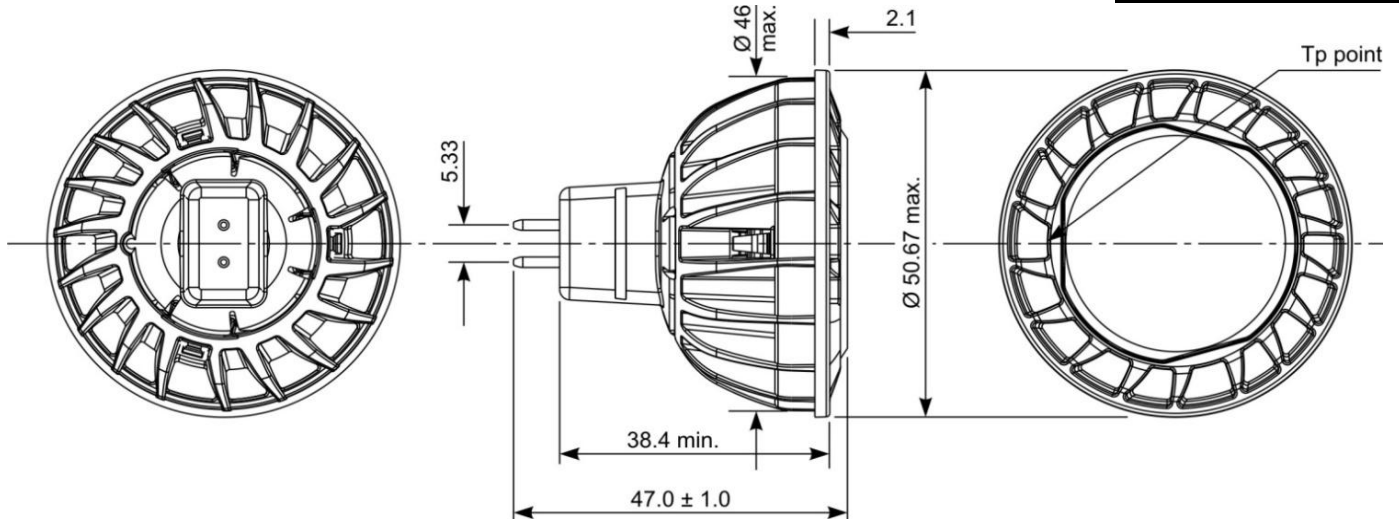

Bulb type : MR16
Cap type : GU5.3

Finish : Dark Silver
Light Colour : 830 Warm White

ELECTRICAL DATA:

		RATED	MIN.	MAX.
Lamp Wattage	(W) :	7.0	-	8.1
Lamp Voltage	(V) :	12	10.2	13.8
Lamp Current	(mA) :	833		
Power Factor	(λ) :	0.7	0.63	-
Supply Frequency	(Hz) :	DC / 50 / 60 / HF		
Energy Consumption per 1000h	(kW/h) :	7.4		

PHOTOMETRIC DATA:

Beam Angle	(°) :	25	19	31
Luminous Intensity	(cd) :	1200	900	1500
Useful Luminous Flux	(lm) :	345	311	-
Useful Luminous Efficacy	(lm/W) :	49		
Correlated Colour Temperature	(K) :	3000		
Colour Rendering Index	(Ra) :	80	77	-
Red Colour Rendition	(R ₉) :	15		
Chromaticity Co-ordinates	(x,y) :	CCx=0.437 CCy=0.404	6-step MacAdam Ellipse	

OPERATING CONDITIONS:

Ta Ambient temperature range	(°C) :	25	-10	45
Tp Point	(°C) :	70	-	90
Starting Time	(s) :	-	-	<0.5
Warm-up Time to >95% Flux	(s) :	-	-	<1.0
Burning Position	:	Universal		
External Control Gear type	:	Halogen Transformer		

LAMP LIFE:

Average Life (L _{70F50})	(h) :	25,000
Switching Cycles	(#) :	100,000

APPLICATION: General lighting. Adaptive thermal control maintains lifetime in enclosed luminaires. Broad compatibility with high frequency electronic transformers. Non-Dimmable. Complies with IEC62838, IEC62612, IEC62471, IEC61547, IEC61000, EN55015, EN62493.

Issued by : TIENEN

Revision date : 23-VII-2014

DATA SHEET

Specification No. : 70-R16-0026306/D

Page : 1 of 2

PHOTOMETRIC GRAPHICS:

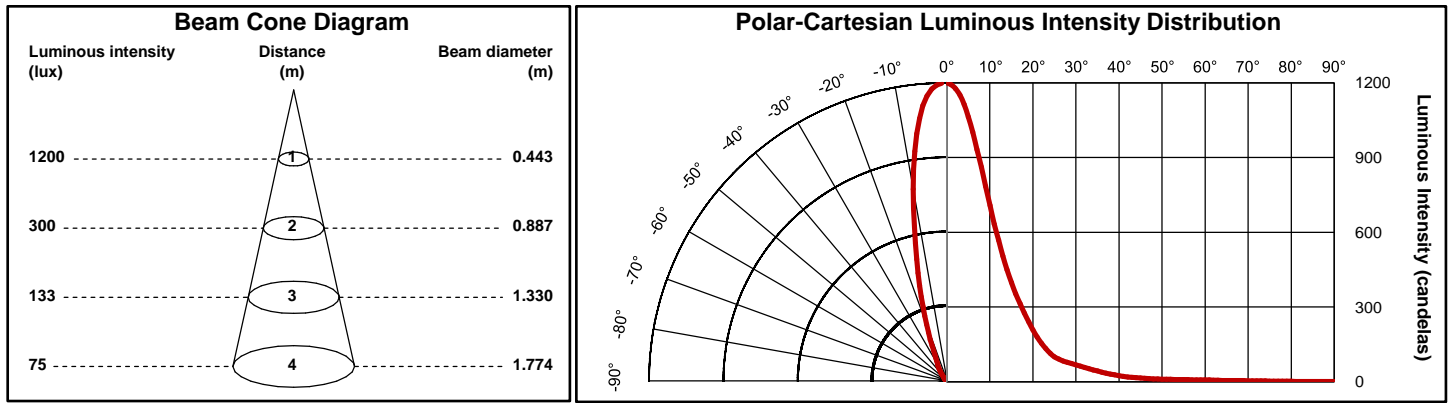

SPECTRAL GRAPHICS:

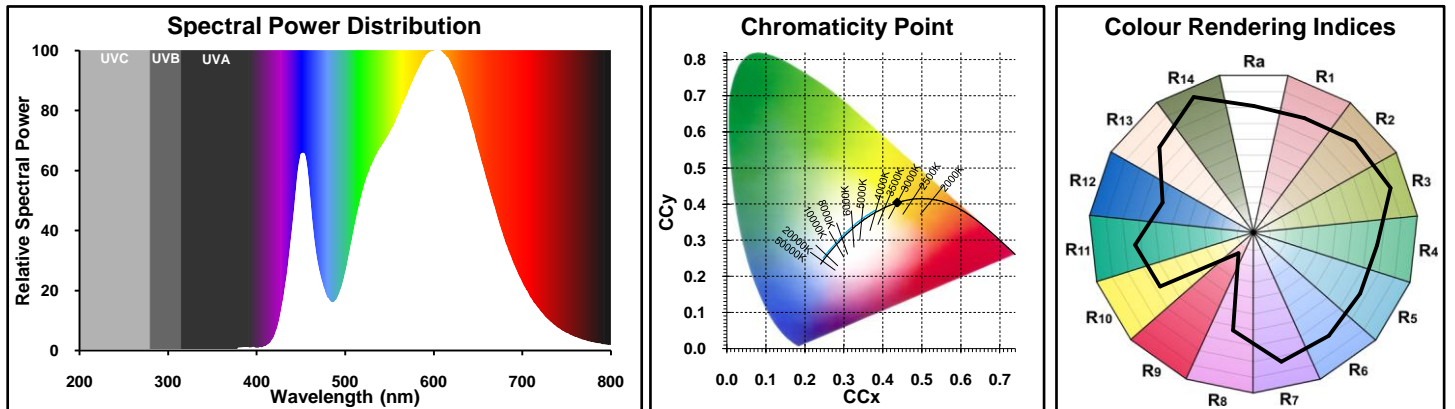

PERFORMANCE GRAPHICS: (Under Consideration)

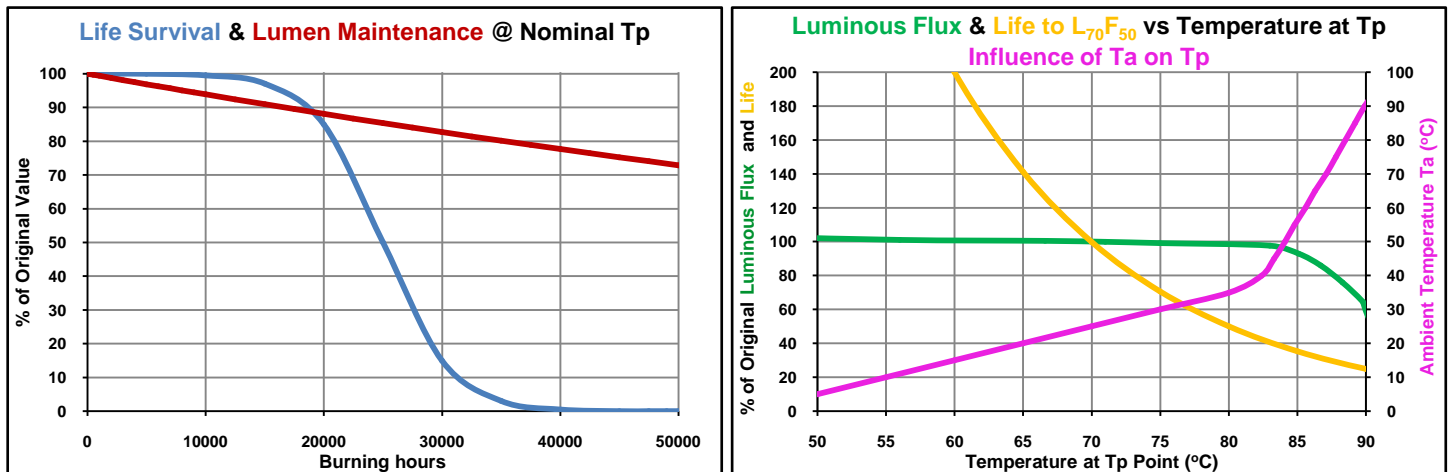

Issued by : TIENEN
Revision date : 23-VII-2014

DATA SHEET

Specification No. : 70-R16-0026306/D
Page : 2 of 2