

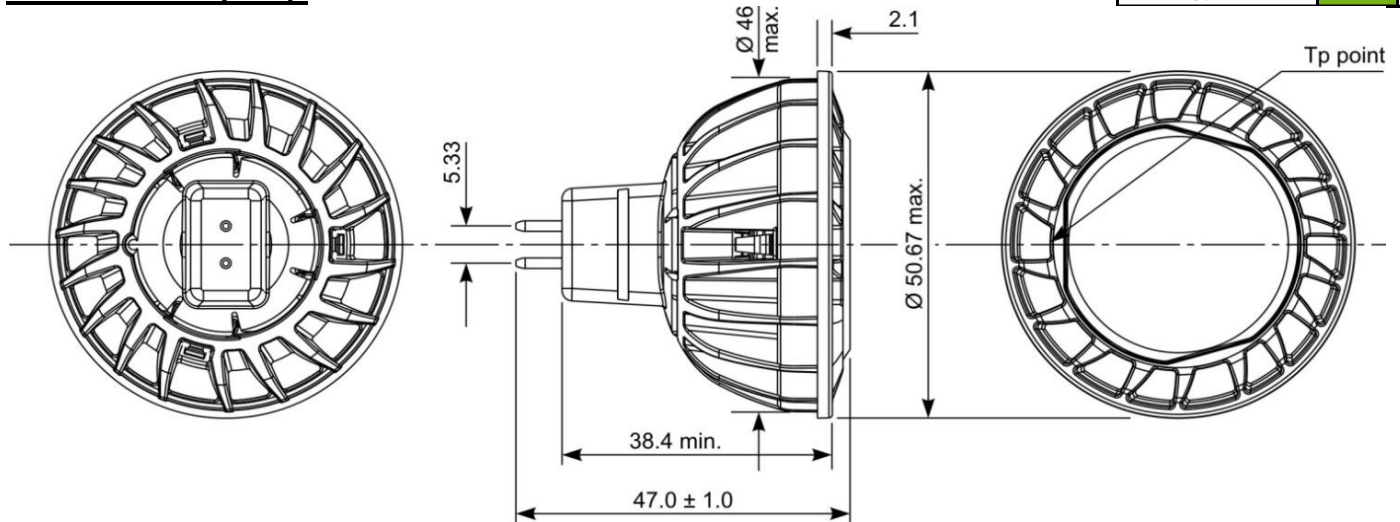

**DIMENSIONS (mm):**

Energy Class : **A+**



Bulb type : MR16  
Cap type : GU5.3

Finish : Dark Silver  
Light Colour : 830 Warm White

**ELECTRICAL DATA:**

		RATED	MIN.	MAX.
Lamp Wattage	(W) :	8.0	-	9.2
Lamp Voltage	(V) :	12	10.2	13.8
Lamp Current	(mA) :	952		
Power Factor	(λ) :	0.7	0.63	-
Supply Frequency	(Hz) :	DC / 50 / 60 / HF		
Energy Consumption per 1000h	(kW/h) :	8.5		

**PHOTOMETRIC DATA:**

Beam Angle	(°) :	40	30	50
Luminous Intensity	(cd) :	930	698	1163
Useful Luminous Flux	(lm) :	621	559	-
Useful Luminous Efficacy	(lm/W) :	78		
Correlated Colour Temperature	(K) :	3000		
Colour Rendering Index	(Ra) :	80	77	-
Red Colour Rendition	(R9) :	10		
Chromaticity Co-ordinates	(x,y) :	CCx=0.428 CCy=0.396	6-step MacAdam Ellipse	

**OPERATING CONDITIONS:**

Ta Ambient temperature range	(°C) :	25	-10	90
Tp Point	(°C) :	80	-	90
Starting Time	(s) :	-	-	<0.5
Warm-up Time to >95% Flux	(s) :	-	-	<1.0
Burning Position	:	Universal		
External Control Gear type	:	Halogen Transformer		

**LAMP LIFE:**

Average Life (L <sub>70F50</sub> )	(h) :	25 000
Switching Cycles	(#) :	100 000

**APPLICATION:** General lighting. Adaptive thermal control maintains lifetime in enclosed luminaires. Broad compatibility with high frequency electronic transformers. Non-Dimmable. Complies with IEC62838, IEC62612, IEC62471, IEC61547, IEC61000, EN55015, EN62493.

Issued by : TIENEN

Revision date : 18-VIII-2015

**DATA SHEET**

Specification No. : 70-R16-0026197/A

Page : 1 of 2

**PHOTOMETRIC GRAPHICS:**

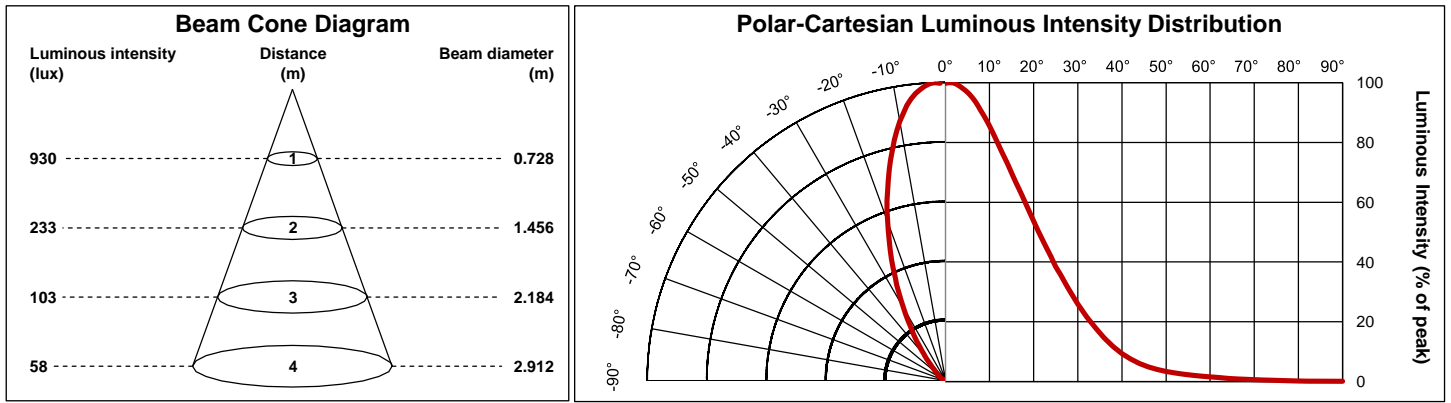

**SPECTRAL GRAPHICS:**

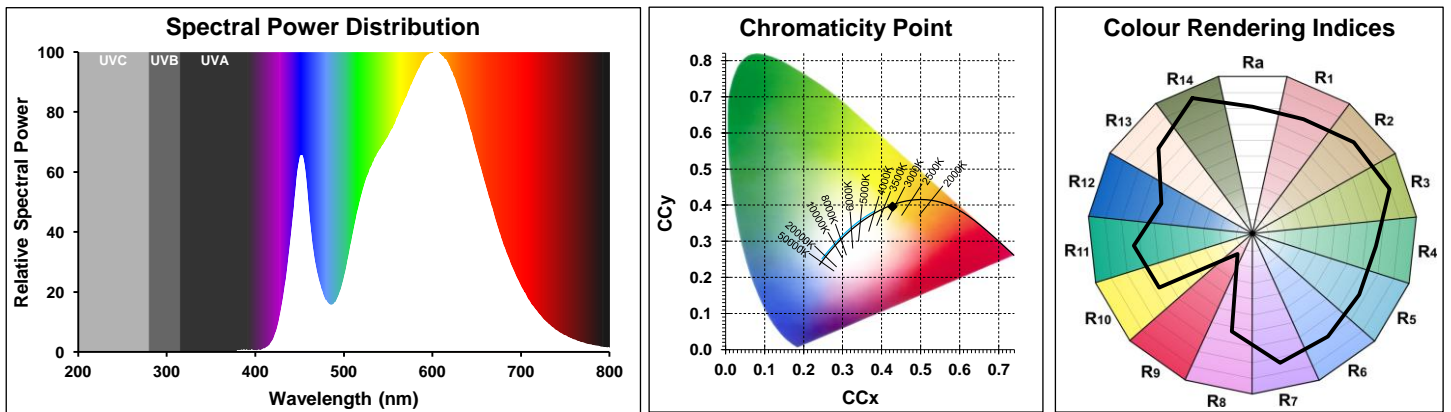

**PERFORMANCE GRAPHICS:**

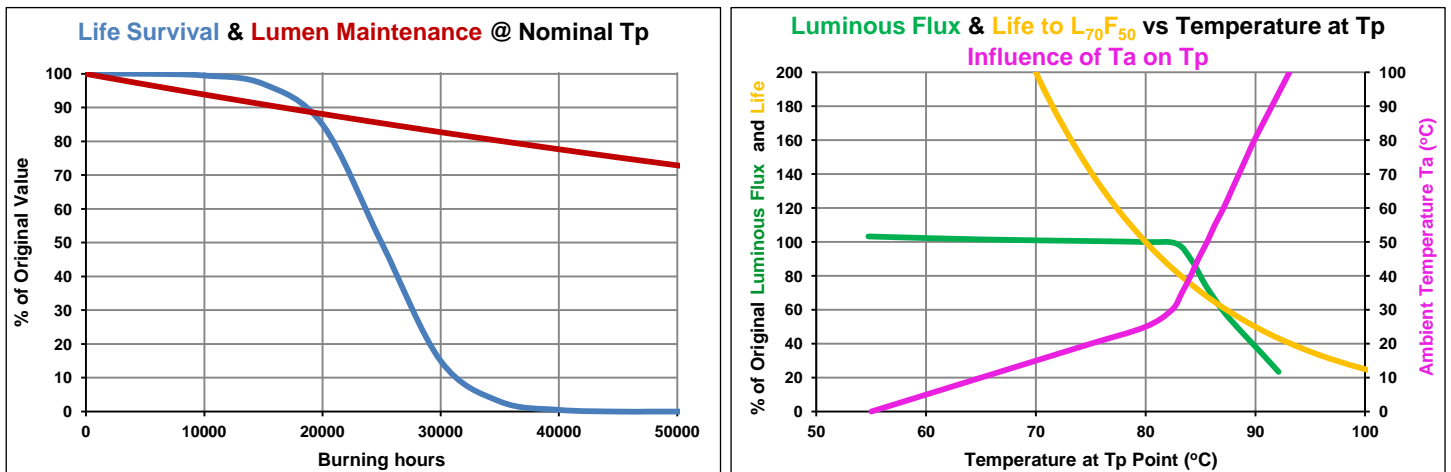

Issued by : TIENEN  
Revision date : 18-VIII-2015

**DATA SHEET**

Specification No. : 70-R16-0026197/A  
Page : 2 of 2